

# MAPEC

MOVING SOLUTIONS



**Piedi fissi**  
base in poliammide rinforzata

Part. **R0600**

- **Best Seller**
- ✔ **Standard**
- **A richiesta**

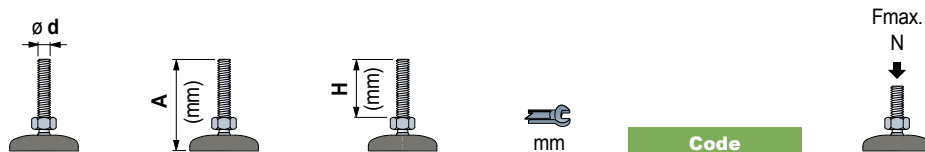

Piedi in acciaio zincato					
M10	50	30	19	68582	2000

**Codice esteso per ordine = Part. + Code**  
 - Materiale base: poliammide rinforzata PA FV (nera).  
 - Confezione: 48 pezzi.  
 - Fmax. = carico max. applicabile in condizioni statiche.

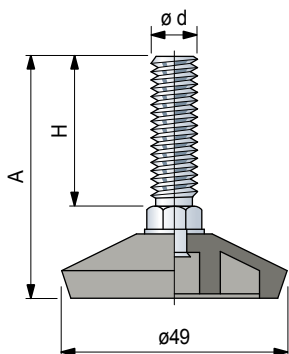

■ **Accessori**

**Dado + Rondella**

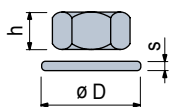

Code		h	Ø D	s
Acciaio zincato		mm	mm	mm
M10	<b>R0000630112</b>	8	17	2

Confezione: 24 pezzi.

# Piedi fissi

base in poliammide rinforzata

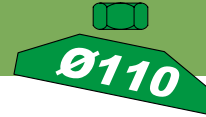

REXNORD

- **Best Seller**
- ✔ **Standard**
- **A richiesta**

Part. **R0031**

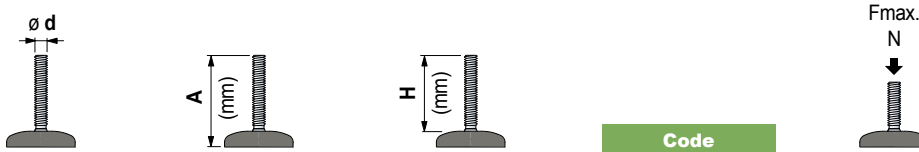

Code



Piedi in acciaio zincato				
M16	101	86	51500	6000

**Codice esteso per ordine = Part. + Code**

- Materiale base: gomma PVC nera (50 Shore).
- Confezione: 20 pezzi.
- Fmax. = carico max. applicabile in condizioni statiche.

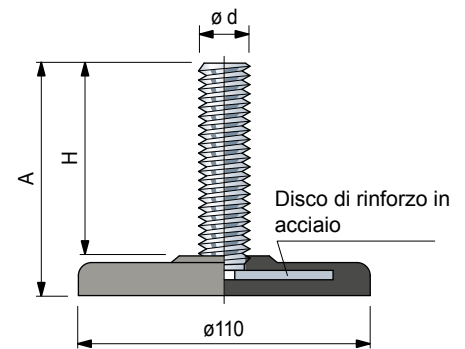

**Accessori**

**Dado + Rondella**

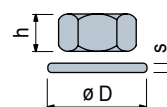

Code

Acciaio zincato	h	Ø D	s
	mm	mm	mm
M16	<b>R0000630142</b>	13	24 30 3

Confezione: 8 pezzi.

**Part. R0403**

- **Best Seller**
- ✔ **Standard**
- **A richiesta**

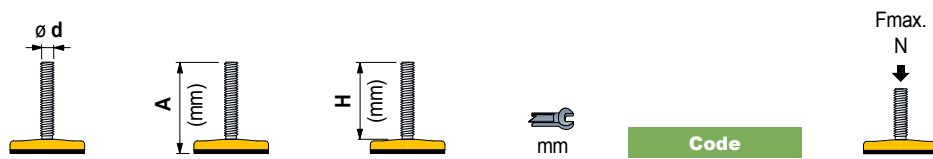

Piedi in acciaio zincato					
M16	A (mm)	H (mm)	mm	Code	Fmax. N
M16	154	128	10	66604	50000

**Codice esteso per ordine = Part. + Code**

- Materiale: base in acciaio verniciato giallo. Antivibrante in gomma NBR nera (durezza 70 Shore).
- Confezione: 8 pezzi.
- Steli con lunghezza diversa a richiesta.
- Fmax. = carico max. applicabile in condizioni statiche.

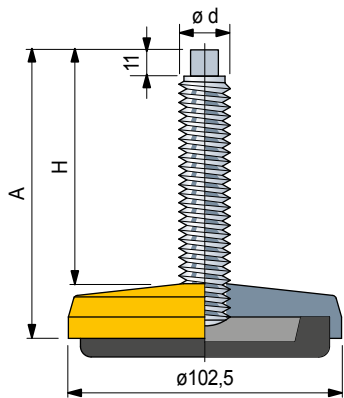

■ **Accessori**

**Dado + Rondella**

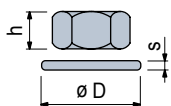

Code		h	ø D	s
Acciaio zincato		mm	mm	mm
M16	R0000630142	13	24	30

Confezione: 8 pezzi.

**Part. R0528**



M16	Code	Fmax. N
M16	644351	50000

**Codice esteso per ordine = Part. + Code**

- Materiale: base in acciaio verniciato giallo. Antivibrante in gomma NBR nera (durezza 70 Shore).
- Confezione: 8 pezzi.
- Fmax. = carico max. applicabile in condizioni statiche.

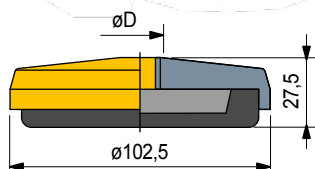

# Piedi fissi

in acciaio verniciato

Ø100

REXNORD

- **Best Seller**
- ✓ **Standard**
- **A richiesta**

Part. **R0406**

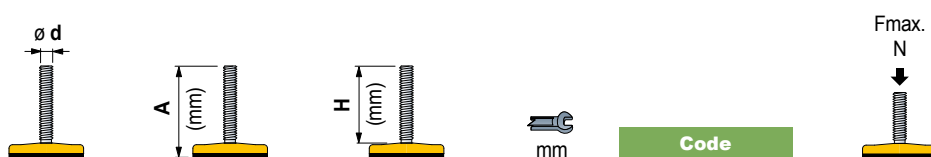

**Piedi in acciaio zincato**

M16	157	127	10	66614	50000
-----	-----	-----	----	-------	-------

**Codice esteso per ordine = Part. + Code**

- Materiale: base in acciaio verniciato giallo. Antivibrante in gomma NBR nera (durezza 80 Shore).
- Confezione: 8 pezzi.
- Steli con lunghezza diversa a richiesta.
- Fmax. = carico max. applicabile in condizioni statiche.

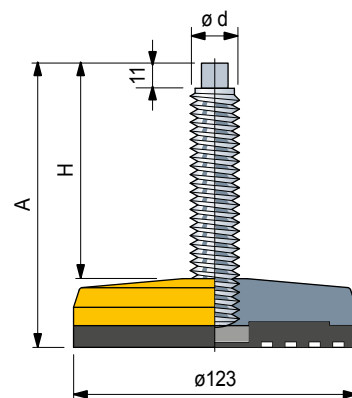

**Accessori**

**Dado + Rondella**

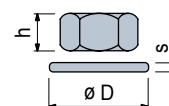

	Code	h	ø D	s
M16	R000630142	13	24	3

Confezione: 8 pezzi.

Part. **R0529**

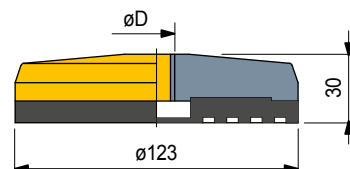

M16	644361	50000
-----	--------	-------

**Codice esteso per ordine = Part. + Code**

- Materiale: base in acciaio verniciato giallo. Antivibrante in gomma NBR nera (durezza 80 Shore).
- Confezione: 8 pezzi.
- Fmax. = carico max. applicabile in condizioni statiche.

Part. **R0383**

Part. **R0384**

Part. **R0399**

Part. **R0385**

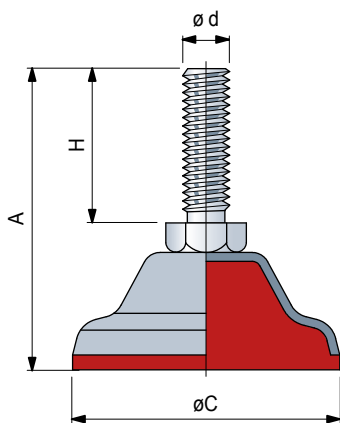

● **Best Seller**

✓ **Standard**

● **A richiesta**

### Part. R0383

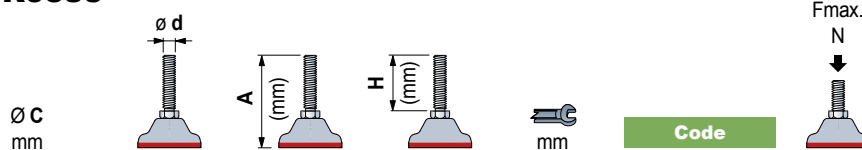

#### Piedi in acciaio inox

	M8	57	30	13	<b>65426</b>	7000
--	----	----	----	----	--------------	------

### Part. R0384

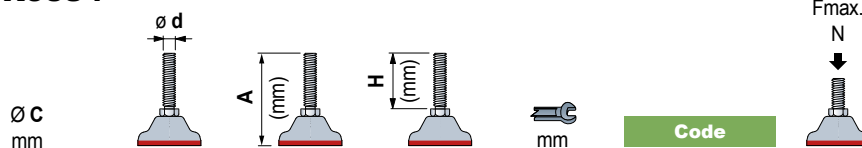

#### Piedi in acciaio inox

	M12	90	50	19	<b>65436</b>	12000
--	-----	----	----	----	--------------	-------

### Part. R0399

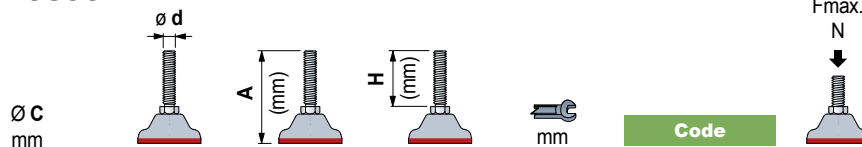

#### Piedi in acciaio inox

	M16	100	60	24	<b>61627</b>	11000
--	-----	-----	----	----	--------------	-------

### Part. R0385

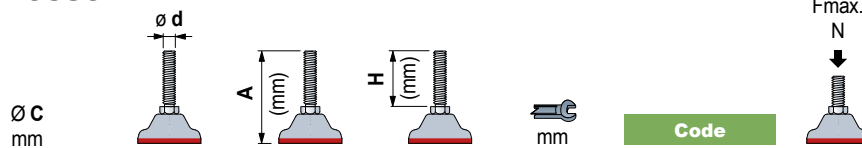

#### Piedi in acciaio inox

	M20	130	70	30	<b>65446</b>	10000
--	-----	-----	----	----	--------------	-------

### Accessori

#### Dado + Rondella

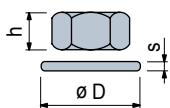

#### Code

	Inox AISI 304	h mm	ØD mm	s mm
M8	<b>R0000654922</b>	6,5	13	1,6
M12	<b>R0000630192</b>	10	19	2,5
M16	<b>R0000630212</b>	13	24	3
M20	<b>R0000630222</b>	16	30	3

Confezione: 8 pezzi.

#### Codice esteso per ordine = Part. + Code

- Materiale: base e stelo filettato in acciaio inox AISI 304. Antivibrante in Adiprene (rosso).
- Confezione: 16 pezzi (per Part. 383). 8 pezzi (per Part. 384 - 399). 4 pezzi (per Part. 385).
- Fmax. = carico max. applicabile in condizioni statiche.

#### Caratteristiche

L'antivibrante in Adiprene ha caratteristiche antiacido e di indeformabilità anche negli impieghi più gravosi.

Piedi da utilizzare su pavimenti umidi e soggetti a soventi lavaggi e sgrassaggi, in presenza dell'azione di prodotti chimici e acidi, dove è necessaria massima pulizia e igiene.

#### Applicazioni

Industria alimentare, lattiero-casearia e della lavorazione della carne.  
Industria chimica e farmaceutica.

---

VIA MONTE BIANCO 15/17  
20833 GIUSSANO - MB

.....  
INFO@MAPEC.NET  
WWW.MAPEC.NET  
T 0362 311684  
F 0362311007